



PROGRAM

A Children's Discovery Center in Lower Price Hill, Cincinnati

SQUARE FOOTAGE

25,000

SITE

16 Acres



CONCEPT

Bridging Gaps.

Knowledge is essentially a matrix of factoids that have been combined into a coherent whole. This design attempts to help the youngest among us to understand the connections between themselves and the world we all live in.

These connections occur at four scales.

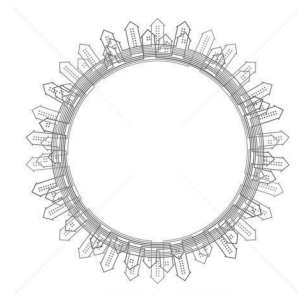
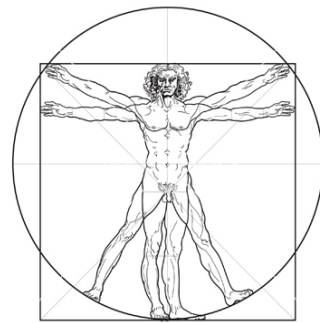

Individuals can learn how their actions not only affect their local surroundings, but the larger community, region, and world. Sustainability is easily teachable and interactive. **Ecology** and **sustainability** make good vehicles for teaching children about their relationship to the world. The form of the building is defined by programmatic requirements, the local topography, and unity with the site.



SITE PLAN

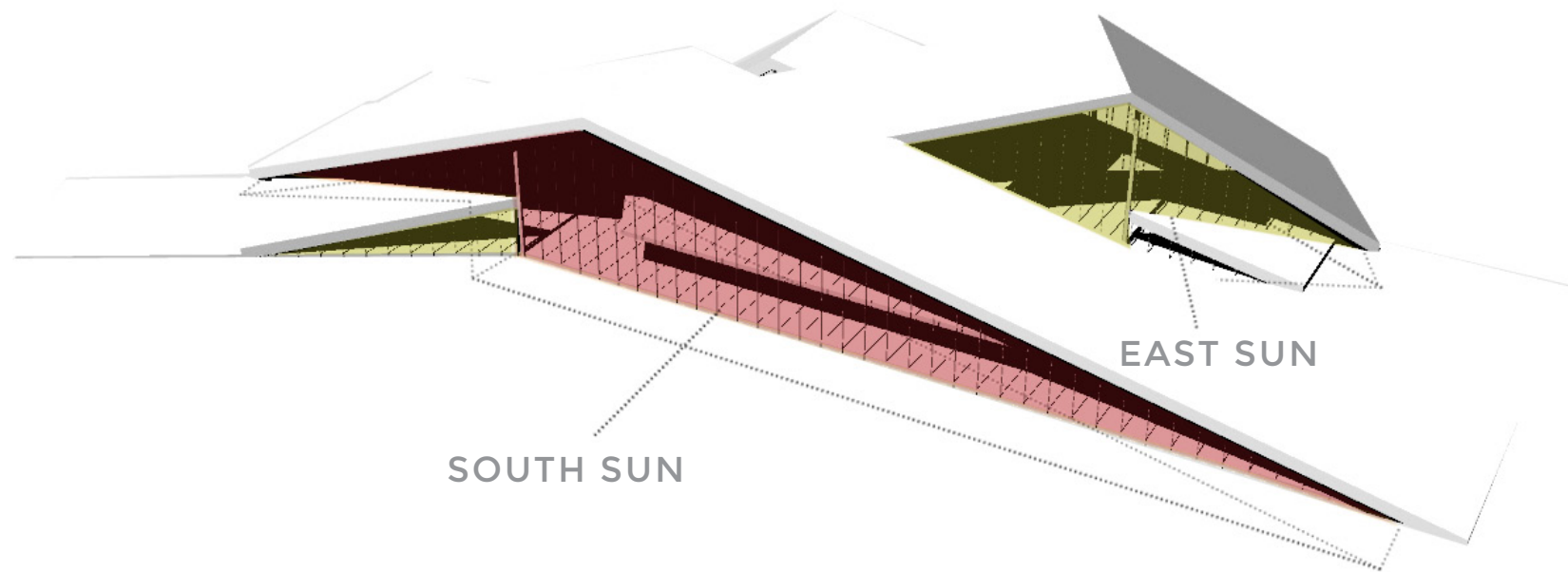

SUN EXPOSURE

FLOOR 2



EXHIBIT
SPACE

ELEVATOR

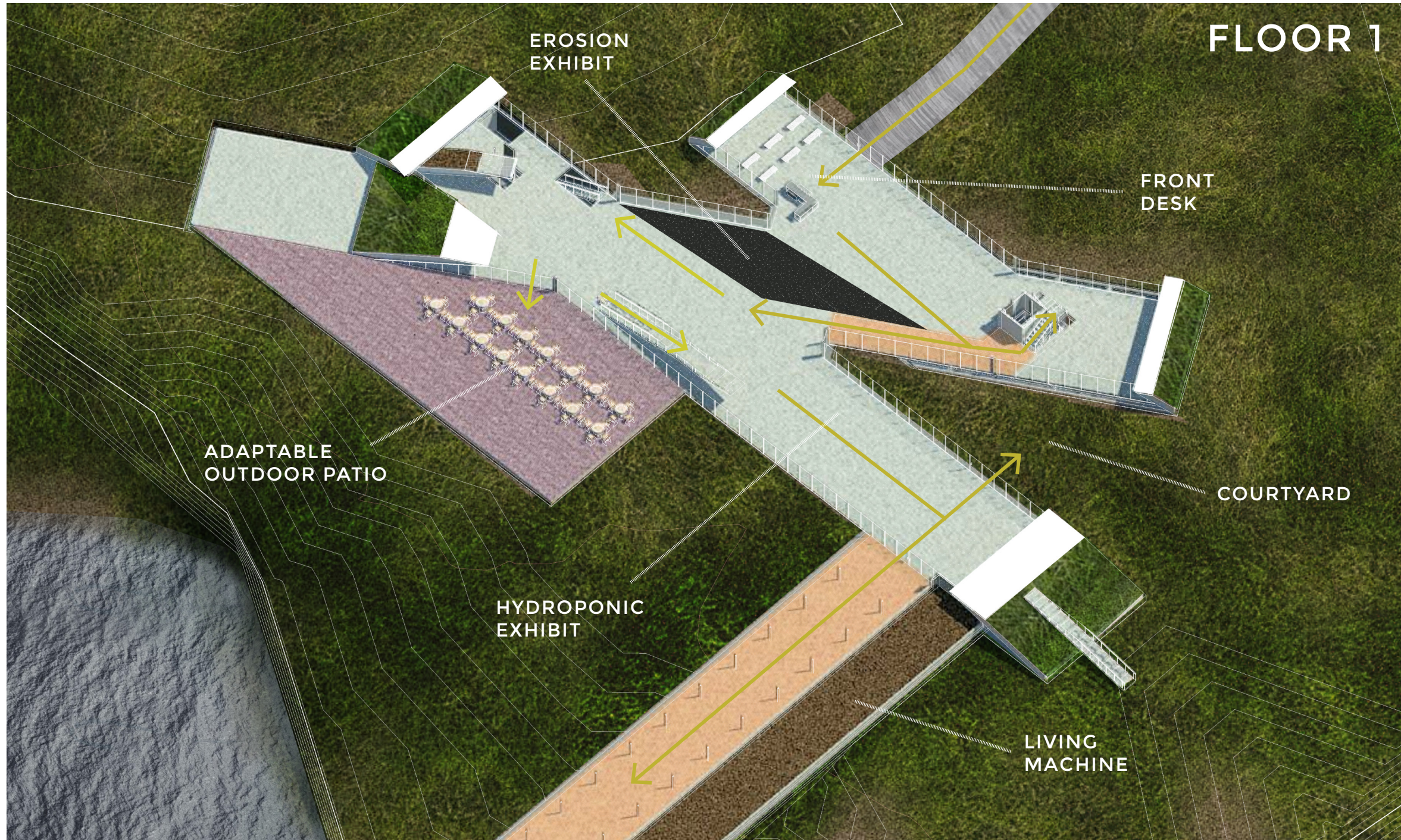

FLOOR 1

EROSION EXHIBIT

FRONT DESK

ADAPTABLE OUTDOOR PATIO

COURTYARD

HYDROPONIC EXHIBIT

LIVING MACHINE

FLOOR B

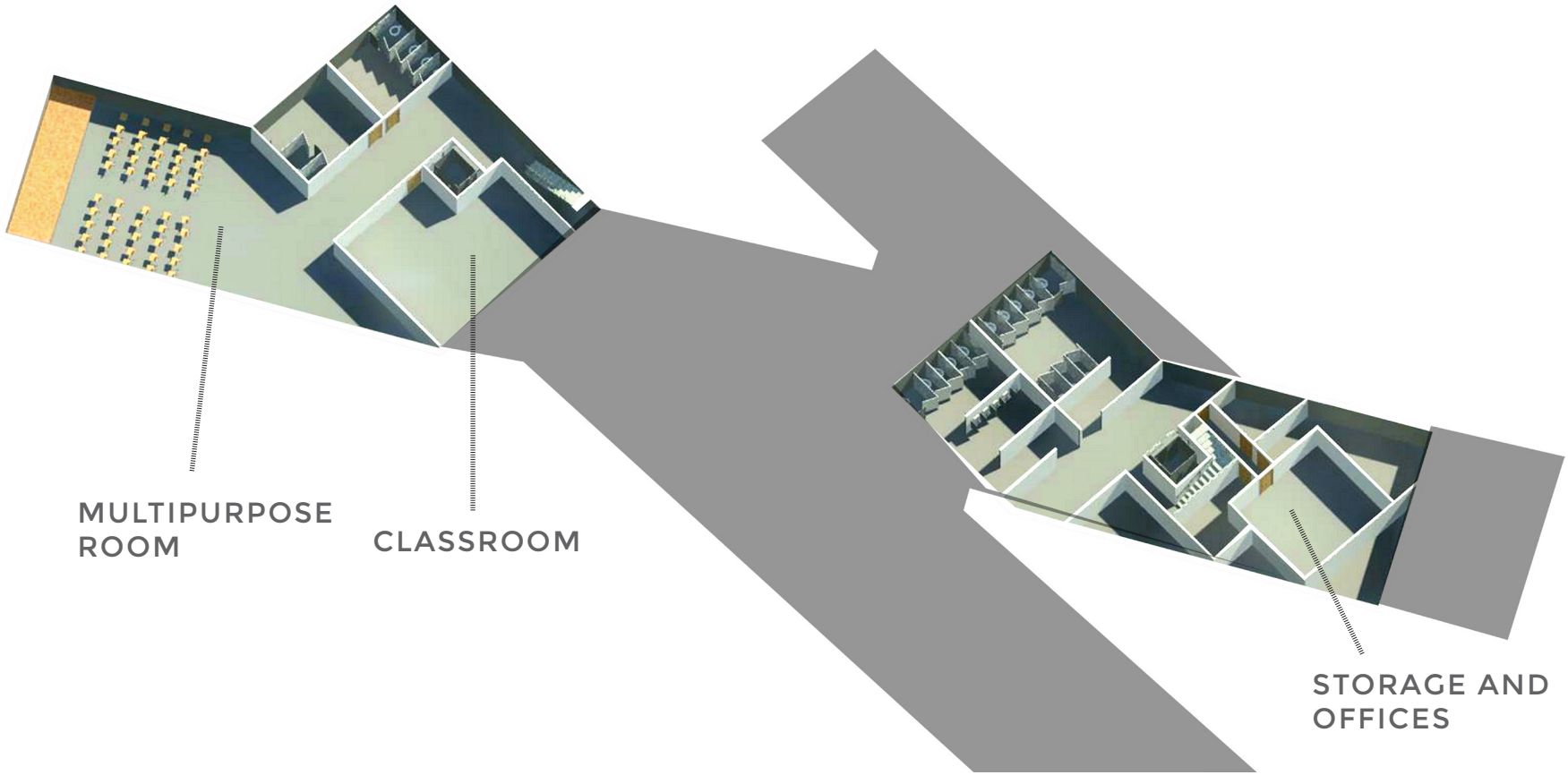

FORM

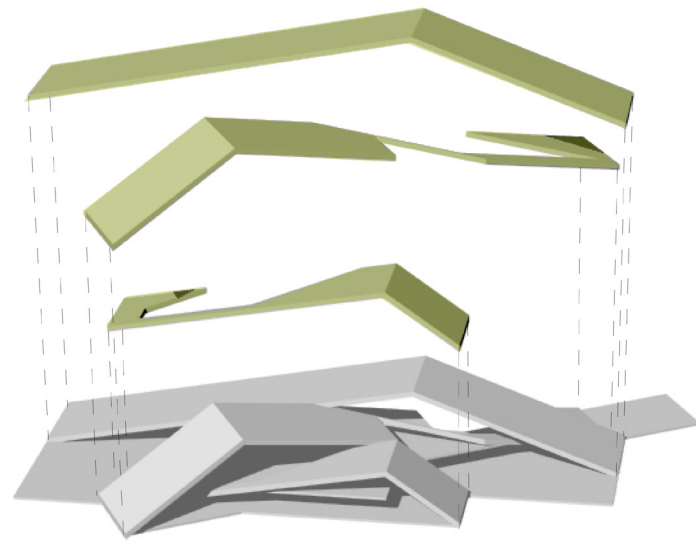
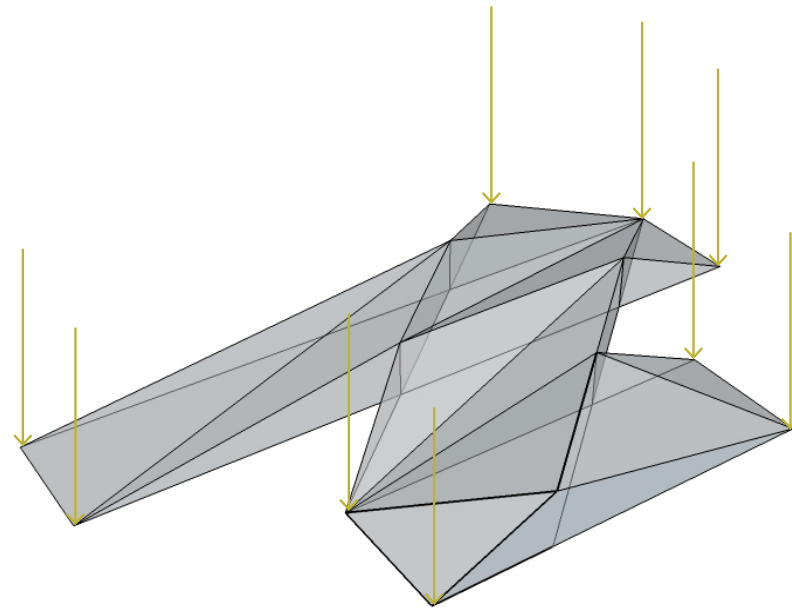
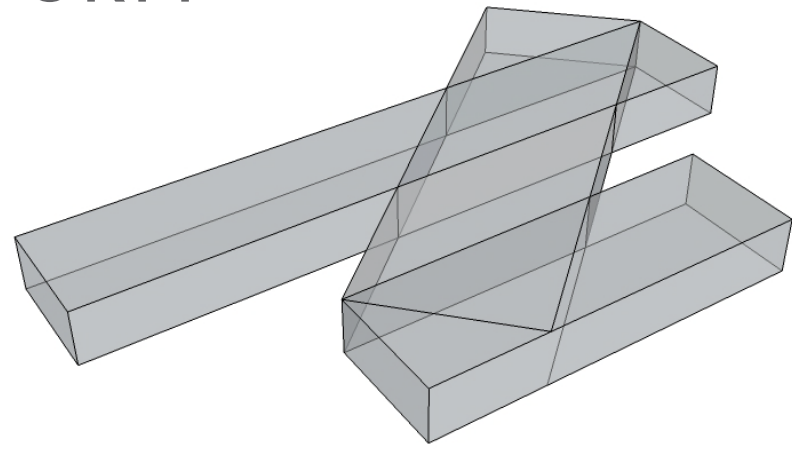

ENTRY PATH

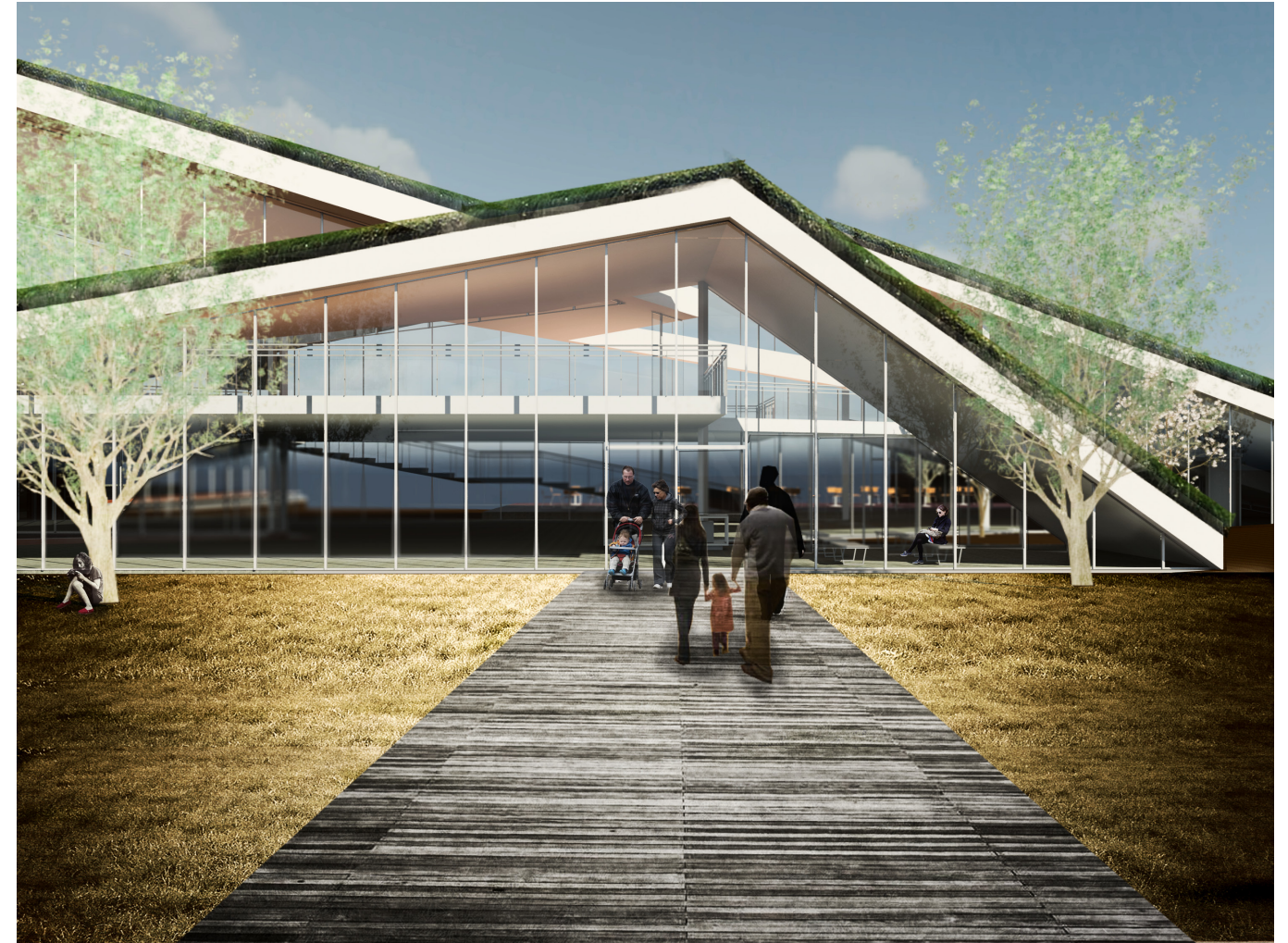

MAIN ENTRANCE

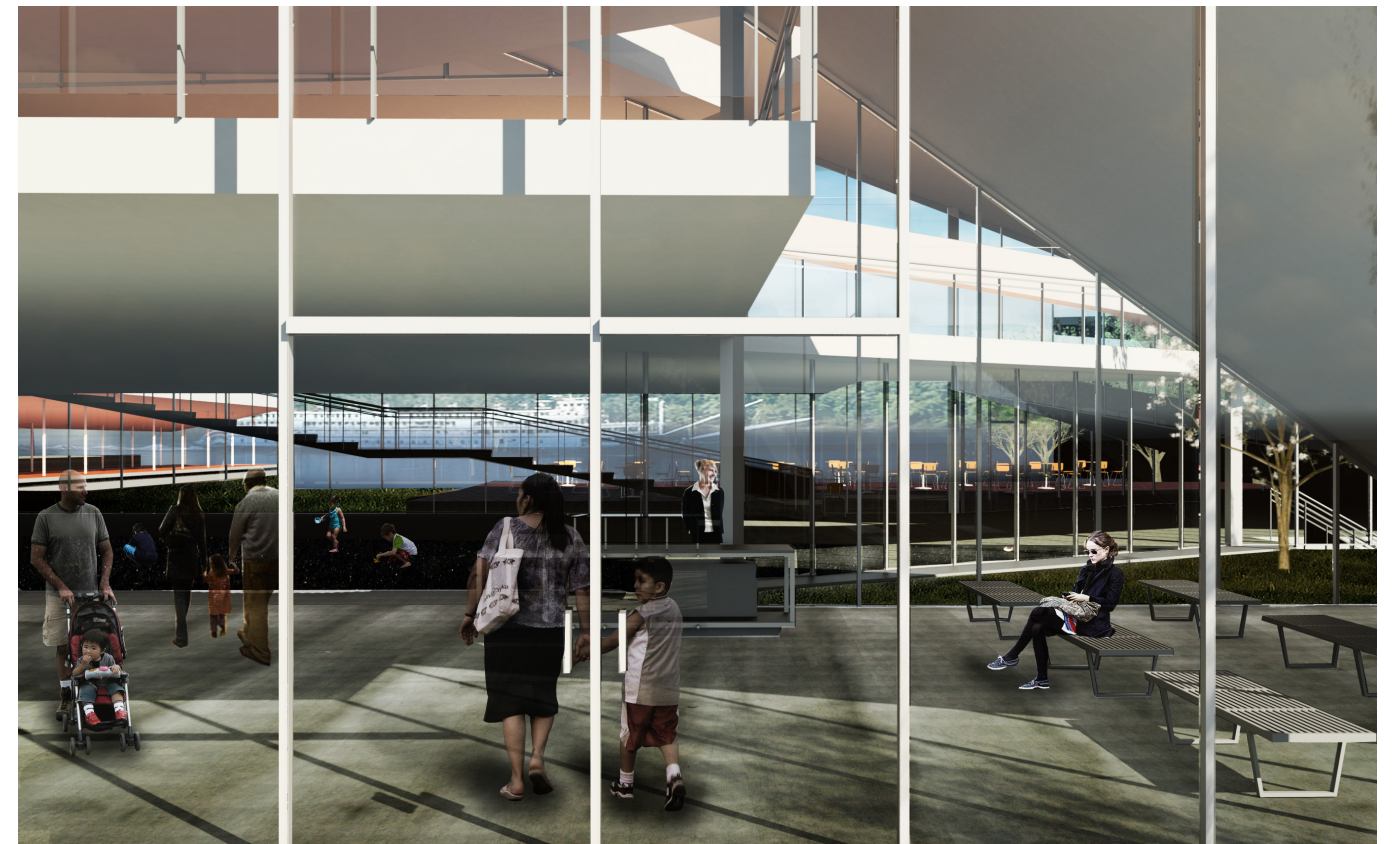

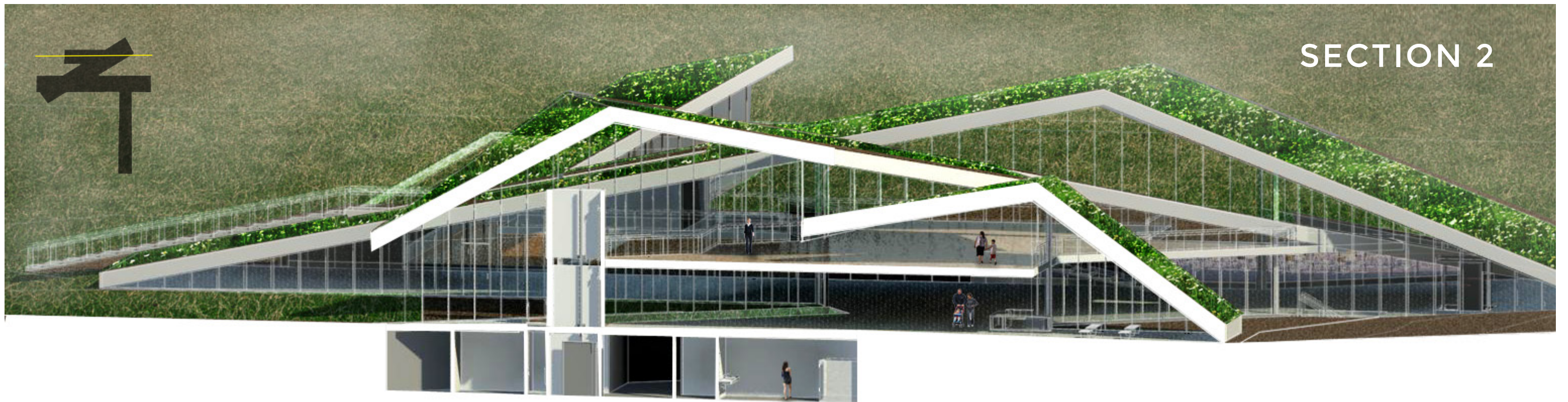
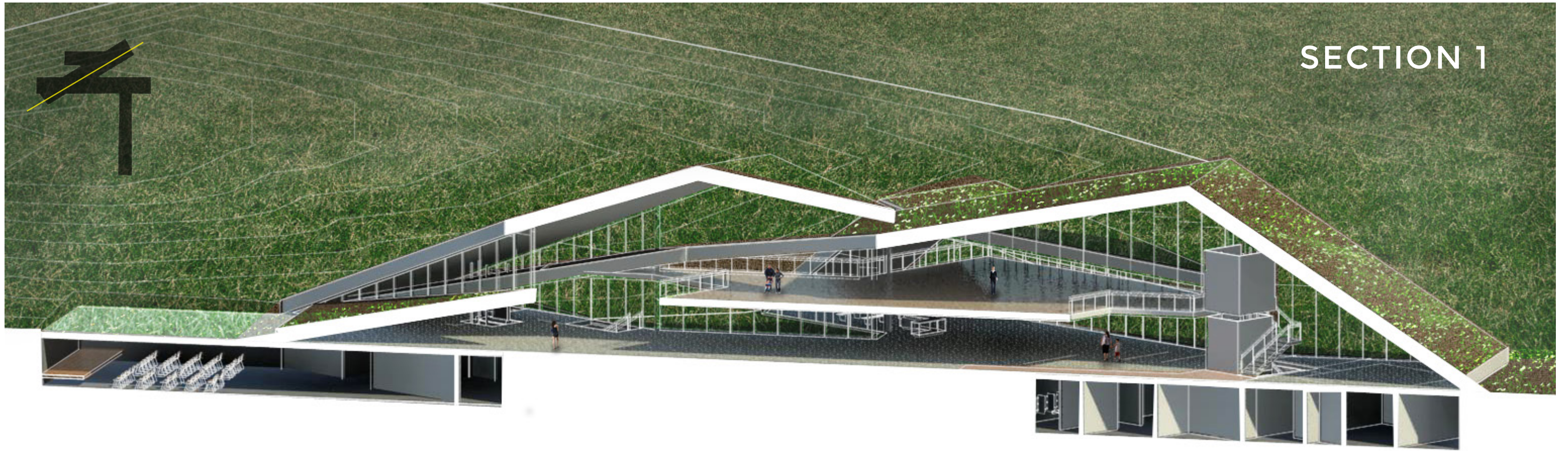

EROSION ZONE



SECOND LEVEL
EXHIBIT SPACE

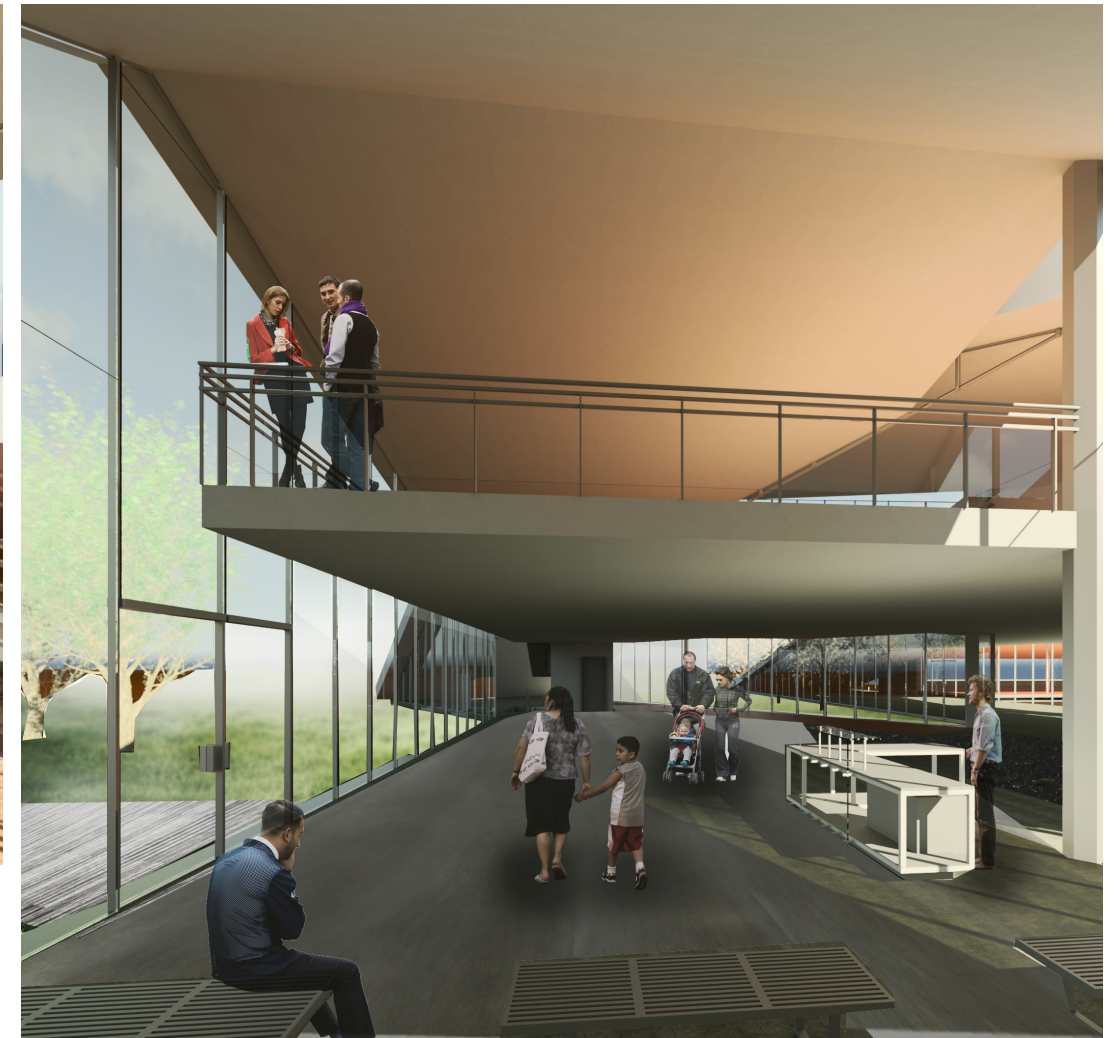

ENTRY



SEATING AREA

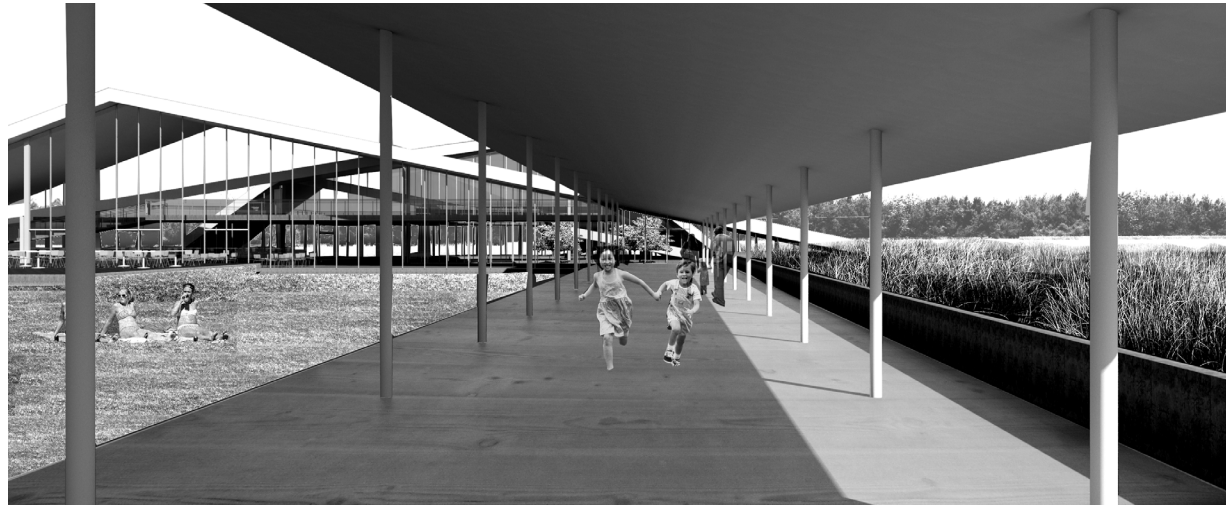
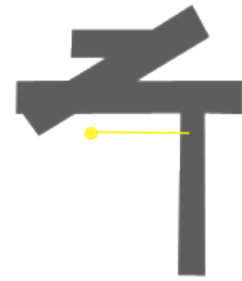

LIVING MACHINE

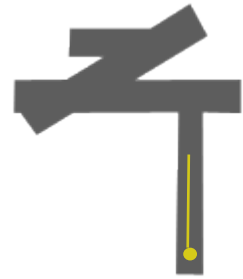

COURTYARD

